

# EXTINTORES AUTOMÁTICOS PARA INCENDIOS PS1-AT, PS2-AT Y PS3-AT ABC

PS1-AT, PS2-AT y PS3-AT son extintores automáticos de polvo de ABC con manómetro.

Las temperaturas de funcionamiento son de 68 o 79 ° C. Certificado según la Directiva de equipos a presión PED 97/23 / EC.

Capacidad 1, 2, 3 kg.

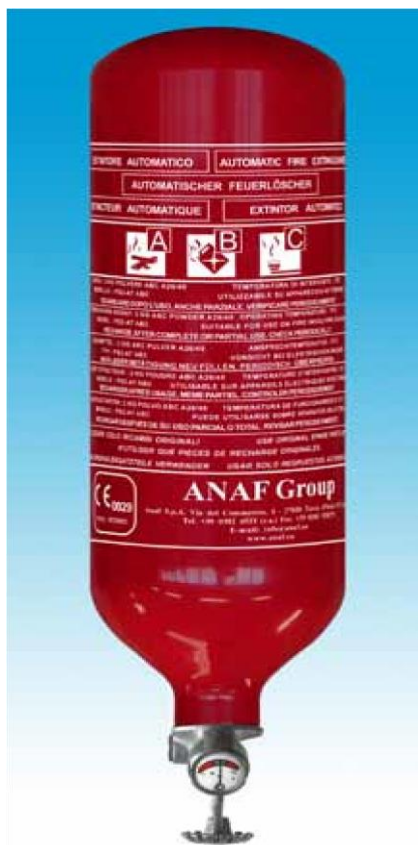

## CONSTRUCCION y USO

### CUERPO DE PS1-AT, PS2-AT •

Cilindro de aluminio, pintado exteriormente con resina de poliéster color rojo RAL 3000.

**CUERPO PS3-AT •** Acero en embutición profunda, pintado exteriormente con resina poliéster color rojo RAL 3000.

**VÁLVULA •** La válvula es de latón plateado tipo sprinkler con manómetro incluido. Todas las partes externas de la válvula están protegidas contra la corrosión.

**PROPELENTE •** El gas propulsor es nitrógeno. Se añade un pequeño porcentaje de helio para facilitar la detección de fuga electrónicamente.

**AGENTE EXTINTOR •** Polvo ABC  
Todas las partes en contacto con el agente extintor son compatibles entre sí.

### SOPORTE PS1-AT, PS2-AT •

Soporte plástico para montaje vertical u horizontal, diseñado también para vehículos y uso marino.

**SOPORTE PS3-AT •** Acero cincado y soporte de techo adecuado para montaje vertical.

### USO

Apto para todos los incendios, excepto los de metal.

## FIRE CLASSES



## Características técnicas

MODEL:	PS1-AT ABC	PS2-AT ABC	PS3-AT ABC	
FIRE RATINGS:	A-B-C	A-B-C	A-B-C	
CHARGE:	1 kg ± 5%	2 kg ± 3 %	3 kg ± 2 %	
PROPELLANT:	nitrogen or nitrogen + helium	nitrogen or nitrogen + helium	nitrogen or nitrogen + helium	
EXTINGUISHING AGENT:	ABC dry powder	ABC dry powder	ABC dry powder	
DISCHARGE:	Discharge time :	6 s	10 s	
	Average throw :	1,5 m at 3 m height	1,5 m at 3 m height	1,5 m at 3 m height
CYLINDER:	Material of construction :	aluminium alloy	aluminium alloy	steel
	Manufacturing process :	deep drawing	deep drawing	deep drawing and MIG welding
	External painting :	polyester resin, minimum thickness 75 µm	polyester resin, minimum thickness 75 µm	polyester resin, minimum thickness 75 µm
	Corrosion resistance :	480 h minimum according to ISO 9227:1990	480 h minimum according to ISO 9227:1990	480 h minimum according to ISO 9227:1990
PRESSURE:	Operating pressure, 20 °C :	13 bar	9 bar	13 bar
	Operating pressure, 60 °C :	15 bar	11 bar	15 bar
	Operating pressure, -30 °C :	11 bar	6 bar	11 bar
DIMENSIONS:	Overall height :	295 mm	380 mm	280 mm
	Bottle OD :	82 mm	108 mm	180 mm
WEIGHT:	Empty / Charged:	0,5 kg / 1,5 kg	0,8 kg / 2,8 kg	1,7 kg / 4,7 kg
PACKING SPEC.:		6 pieces cardboard box	4 pieces cardboard box	single piece cardboard box
	Carton size : B x L x H :	265 x 200 x 320 mm	240 x 240 x 400 mm	200 x 190 x 320 mm
	Volume :	0,017 m <sup>3</sup>	0,023 m <sup>3</sup>	0,013 m <sup>3</sup>
	Weight per carton :	9,5 kg	12,5 kg	5,2 kg
	Pallet :	90 cartons (540 pieces)	60 cartons (240 pieces)	72 cartons
	Pallet size : B x L x H :	800 x 1200 x 1745 mm	800 x 1200 x 1750 mm	800 x 1200 x 1550 mm
	Pallet volume :	1,68 m <sup>3</sup>	1,68 m <sup>3</sup>	1,49 m <sup>3</sup>
	Weight per pallet (net/gross):	855 kg / 875 kg	750 kg / 770 kg	706 kg / 726 kg

DATA AND CHARACTERISTICS SHOWN ON THIS TECHNICAL SPECIFICATION MAY THEREFORE BE MODIFIED IN ANY MOMENT WITHOUT NOTICE

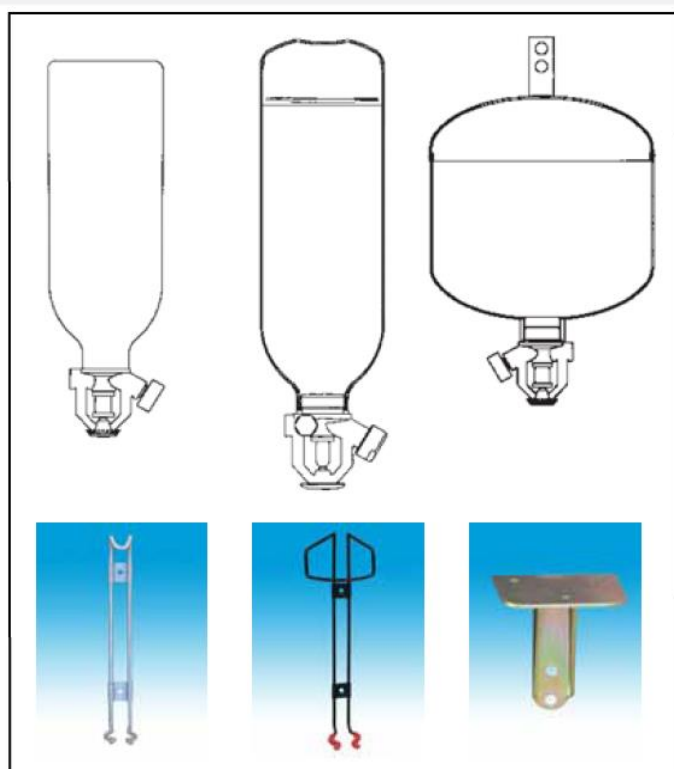

www.anaf.eu - e-mail: info@anaf.eu

SENSING ELEMENTS		
GLASS BULB COLOUR	OPERATING TEMPERATURE	
Orange*	57°C	135F
Red	68°C	155F
Yellow	79°C	175F
Green*	93°C	200F
Blue*	141°C	288F

\*Only available on demand